



R2

VECTAPURE NX™

Residential Reverse Osmosis Water System

INSTALLATION AND OWNER'S MANUAL FOR MODELS RO4053HNX, RO405400TNX AND RO405400NX

THIS MANUAL IS TO BE LEFT WITH THE OWNER OF THE EQUIPMENT FOR REFERENCE PURPOSES AND TECHNICAL GUIDANCE. IT IS STRONGLY RECOMMENDED THAT QUALIFIED DEALER SERVICE PERSONNEL BE CONTACTED IN THE EVENT OF AN UNKNOWN INTERRUPTION OF SERVICE OR APPARENT PRODUCT MALFUNCTION. AN ANNUAL PREVENTATIVE MAINTENANCE INSPECTION BY A WATER PROFESSIONAL IS RECOMMENDED TO ENSURE TROUBLE-FREE AND CONTINUOUS OPERATION.



Congratulations!

You have purchased the finest residential reverse osmosis water system available for your home. It will provide you years of reliable service if properly installed, operated and maintained. Please read this entire manual before attempting installation and operation.

Section 1. Frequently Asked Questions

Before getting started, take the time to familiarize yourself with your new Waterite system by reading some FAQs listed below. Call us or ask your dealer if you have any other questions about your system's operation.

Q: How does the Vectapure NX™ Residential Reverse Osmosis System differ from an ordinary water filter?

Ordinary water filters use a screen to separate only particles of dirt and sediment from the raw water source. Reverse osmosis employs a semi-permeable membrane that removes not only particles but also a very high percentage of dissolved contaminants, molecule by molecule, from your raw tap water. Your system will deliver pure, bottled-water quality water to a faucet conveniently located at your kitchen sink or any other designated area.

Q: What is the membrane and how does it work?

The membrane element consists of several thin layers or sheets of film that are bonded together and rolled in a spiral configuration around a plastic tube. As the raw water passes across the surface of the membrane, only pure water molecules are allowed to pass through and collect in the tube, while all other mineral and contaminant molecules are rejected and washed from the surface of the membrane to the drain.

Q: What processes does the Vectapure NX™ RO system use?

Vectapure NX™ system uses 5 stages of treatment to produce your drinking water. The raw tap water first flows through a 5-micron particle filter to remove suspended solids, the second and third stage are 5-micron carbon blocks which help to remove/reduce chlorine, chloramine and VOC. The fourth stage is the reverse osmosis membrane that separates most dissolved contaminants from the water molecules. The final stage is an in-line carbon filter that eliminates all remaining traces of taste and odour that the water may have absorbed from the holding tank or the plumbing system. Your system also includes a holding tank for the purified water, a faucet and the hardware and tube needed to complete the installation.

Q: Will reverse osmosis remove sodium and salts from the water?

Yes. Reverse osmosis was originally developed to make drinking water from seawater. Your system is equipped with a membrane that will be very effective in reducing sodium levels normally found in ground water or softened water. This is particularly important for those with restricted sodium diets. Vectapure NX™ system is not designed for use on seawater.

Q: Does reverse osmosis remove bacteria? Cryptosporidium? Viruses?

Reverse osmosis membranes will virtually eliminate most chemicals, bacteria, viruses and parasites such as Cryptosporidium from the water. Where these conditions exist, pre-filters and other system components located before the membrane will become contaminated from exposure to them. Cross contamination of the entire system may occur when the membrane or filters are changed or disturbed. It is recommended to clean and sanitize your system including kitchen faucet at least once per year or every time you do a filter change. **Make sure that you carefully follow the maintenance instructions provided.**



THIS REVERSE OSMOSIS WATER SYSTEM IS DESIGNED ONLY TO IMPROVE AESTHETIC PROPERTIES AND IS NOT DESIGNED TO ACT AS A PRIMARY BARRIER TO WATERBORNE MICROBIOLOGICAL OR TOXIC CHEMICAL CONTAMINATION. WHERE THESE CONDITIONS MAY EXIST CONSULT A WATER PROFESSIONAL TO ENSURE SUFFICIENT RAW WATER PRE-TREATMENT AND DISINFECTION.



WATERITE RO SYSTEMS ARE TO BE OPERATED ONLY WITH A SAFE, CHLORINATED RAW WATER SOURCE. THIS IS NECESSARY TO PERIODICALLY PURGE AND FLUSH THE SYSTEM WITH WATER THAT HAS A CHLORINE RESIDUAL TO SANITIZE PARTS OF THE SYSTEM THAT NORMALLY ARE EXPOSED TO WATER THAT HAS BEEN DECHLORINATED AND MAY BE SUSCEPTIBLE TO BACTERIAL CONTAMINATION. FOLLOW CLEANING & SANITIZING INSTRUCTIONS AND CHANGE FILTER CARTRIDGES AT RECOMMENDED INTERVALS.

Q: What other contaminants does reverse osmosis remove?

The combined filtering and RO processes in your system will remove more than 98% of many organic compounds, including THMs (chloroforms), DBCP, lindane, TCE (trichloroethylene), PCE (tetrachloroethylene), carbon tetrachloride and chlorine. Conservatively, Vectapure™ TFC membranes will remove the following percentages of contaminants: Barium 97%, Potassium 92%, Bicarbonate 94%, Radium 97%, Cadmium 97%, Selenium 97%, Calcium 97%, Silicates 96%, Chromium 92%, Silver 85%, Copper 97%, Sodium 92%, Detergents 97%, Strontium 97%, Fluoride 90%, Sulphates 97%, Lead 97%, PCBs 97%, Magnesium 97%, Insecticides 97%, Nickel 97%, Herbicides 97%, Nitrates 80%, Total Dissolved Solids 97%.

Q: What does RO treated drinking water taste like?

As most of the chemicals, organics and minerals are removed, your water will taste similar to distilled water or low-mineral bottled water. Most people enjoy the natural flavour and the soft texture. You will immediately notice that brewed coffee and juices from concentrate have a greatly enhanced taste and aroma.

Q: Where is the system installed?

Typically, the system is installed under the kitchen sink. Some homeowners or installers prefer the basement or crawlspace, as this conserves storage in the kitchen and may allow for easier access to the system for maintenance purposes.

If you install the system more than 20' from your faucet, you may need a product water booster pump to ensure adequate pressure at the faucet. Your dealer can provide you with this optional equipment.

Q: Can the Vectapure NX™ system be connected to an extra faucet?

Yes. Many installations will include an optional ¼" line to refrigerator icemakers or additional sink faucets. See your dealer for advice and parts.

Q: What factors affect the quantity and the quality of the water produced?

1. Pressure: The greater the water system pressure, the greater the water quantity that will be produced. 60PSI is optimal, but system pressure should never exceed 80PSI. Where water pressures are low (<40PSI), a booster pump on the raw water line can be added to increase production. Your system is equipped with a pressure regulating device that will, when installed, limit the raw water pressure delivered to the system to about 60PSI.
2. Temperature: Production increases with temperature, the optimal being 76F. Never operate the system from the hot water line or with water exceeding 85F, as this will damage the membrane.
3. Membrane type: Vectapure NX™ system uses premium quality TFC (Thin Film Composite) membranes, specially chosen for household applications.
4. TDS: The higher the Total Dissolved Solids in the raw water, the lower the output of product water.

Q: How much water does the Vectapure NX™ system produce?

RO4053HNX systems use membranes nominally rated for 75GPD; RO405400NX™ systems are rated for 400GPD. Actual output will be dependent upon the factors explained above. In optimal applications (with a booster pump) you may expect 60-70 gallons/320-400 gallons (400NX™ systems) to be available over 24 hours.

Q: Can the amount of water produced be increased?

Filling a water pitcher for the refrigerator will allow more production overnight. A larger holding tank (available from your dealer) will allow for more water to be on hand. Booster pumps will also increase daily production.

Q: What is the standard warranty with the Vectapure NX™ system?

Every Vectapure NX™ system comes with a standard one-year limited warranty on all parts and repair labour. A detailed warranty card is included with the unit. **You may purchase and extended warranty if you wish - see the enclosed Extended Warranty Program information sheet and enrolment form included in your package. Call your dealer if you wish to have one sent to you.** Normal filter cartridge replacement is excluded from your warranty.

Q: What is the maintenance schedule for the Vectapure NX™ system?

A good rule of thumb is to replace all pre-filters every three months. This is critical to ensure that chlorine does not attack the membrane film. The carbon post-filter should be changed every three to six months. When the old cartridges have been removed, the system should be cleaned and sanitized with chlorinated water before the new cartridges are installed. Dependent upon local water conditions, your membrane should have a life expectancy of 1-5 years. More severe water conditions (iron, hardness) may shorten this significantly; soft water sources may allow a membrane life of up to 8 years.

Q: When should the membrane be changed?

If you notice gradually decreasing production from your system, differing taste to your drinking water or a white scale forming on pans or dishes, it probably means that your membrane is deteriorating and is losing its effectiveness. You may purchase a pocket TDS meter from your dealer - this is the best way to assure you system is operating efficiently. (The RO405400TNX models come with a TDS meter preinstalled).

Section 2. Unpacking and Installation

Your system includes:

Carton Contents

- ✓ The main 5 stage RO/filter unit assembly;
- ✓ One encapsulated membrane (pre-installed), one sediment filter cartridge, two block carbon filter cartridges;
- ✓ One drain fitting and clamp with push-on tube fitting;
- ✓ One cold water supply adapter;
- ✓ One long reach faucet with mounting hardware;
- ✓ Two #10 X1" Wall mounting screws;
- ✓ 5 m (15') - white ¼" Poly tubing for water connections;
- ✓ 3m (10') – black ¼" Poly tubing for drain connections;
- ✓ One plastic tank shut-off valve;
- ✓ One filter housing wrench;
- ✓ One Owner's package including owner's manual, warranty certificate, Extended Warranty Plan enrolment form;
- ✓ One 12 litre (3.2 gallon) RO holding tank.
- ✓ One Leak Stop flow interrupter
- ✓ One shock arrestor/pressure regulator device

Step 1. Selecting the System Location

1. This reverse osmosis system is designed for installation under a sink. It can however, be mounted anywhere within 20 feet of the faucet, such as the basement or adjoining utility room. Keep in mind that filter housings will need periodic replacement and that easy access must be maintained. Do not install in a location with high humidity, direct sun or a direct source of heat. Both the RO system and the tank may be installed horizontally or vertically. If you are installing a booster pump for your system, you will need a standard 110V plug nearby.

Figure 1.



Keep in mind that you may install a tube tee on the line to the faucet to connect icemakers or other faucets to the system. If you locate your system farther than 20 feet from the faucet, you will need to use 3/8" tubing or install a pressure booster pump to your line. See your dealer for parts and details.

Step 2. Getting Ready

1. Clear working area. Unpack all components and check for visual damage. Ensure all listed components are included.
2. Inspect the cold water supply line and the condition of the pipe. The water supply adapter included is intended to be installed between the supply valve and the faucet connector, under the kitchen sink. If the cold water supply valve is not available at the installation location, you will need to consult your plumber or plumbing supply store to purchase an appropriate cold water connection.
3. Check the air pressure in the RO storage tank with an ordinary tire gauge. It should be pre-charged to 7-10 PSI. Adjust if necessary. **DO NOT EXCEED RECOMMENDED TANK INFLATION PRESSURE – UNIT WILL FAIL TO OPERATE CORRECTLY.**
4. You will need the following tools: An electric drill, a 1/2" carbide bit, a 1/4" carbide bit, a 1/8" carbide bit, a pencil, a small adjustable (crescent) wrench, a sharp knife (X-Acto type knife is best), Teflon plumbing tape, adjustable pliers, a rat-tail file, a center punch, a medium flat head screwdriver, a small household funnel. **Always wear eye protection when using an electric drill.**

Step 3. Install the Cold Water Supply Faucet Adapter

1. Turn OFF the COLD water supply valve to your kitchen faucet.
2. Turn ON the COLD water on your kitchen faucet to release all the pressure, and completely drain the cold water until the water flow stops.
3. Place some towels underneath the cold water supply valve and then disconnect the faucet supply tube from the cold water supply valve.
4. Wrap male threads on both cold water supply valve and the water supply adapter 4 to 5 times with plumber's (Teflon) tape.
5. Install the water supply adapter on the cold water supply valve. Do not over-tighten.
6. Install the faucet supply tube to the water supply adapter.

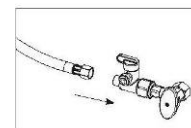
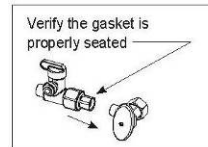
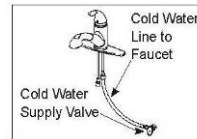

7. Connect the white ¼" tube to the water supply adapter by inserting the tube firmly and pushing until the tube end contacts the stop. Gently tug the tube backwards to assure a secure connection. Do **NOT** connect the other end of the tube to the RO system water inlet at this time.

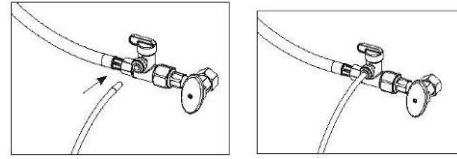

8. Keep the **COLD** water supply valve **OFF** until the RO system installation has been completed.

Step 4. Install the Sink Faucet

Tools required for this step: An electric drill, a 5/8" carbide bit, a small adjustable wrench, a center punch, a pencil, a rat-tail file.

1. Examine the sink. If it has an existing hole for mounting a faucet, skip to Step 4. (6).
2. Locate and mark the spot you wish to install the faucet. Make sure it does not interfere with operation of the main faucet and that there is clearance for plumbing and mounting hardware directly below it under the sink or countertop. If you have a stainless sink, go to Step 4. (5)
3. If you have a concrete sink with a thickness of less than 1", the faucet can be mounted directly to sink. If the thickness exceeds 1", the faucet must be mounted directly on the countertop or a faucet with an extended shank must be used. *Tool substitution: Use a 5/8" masonry bit to drill the concrete sink.*
4. If you have a porcelain enamel or ceramic sink, it is **strongly** recommended that a professional install the faucet to avoid chipping and damaging the sink finish.
5. Mark the spot chosen for the faucet hole with the pencil. Use the center punch to slightly indent the spot (the center punch is unnecessary for concrete sinks). Use the 5/8" bit and drill the hole. Use the rat-tail file to smooth any burrs or rough edges on the hole.
6. The sink faucet may now be assembled to the sink or countertop using the assembly procedure shown in Figure 2. Your faucet may have the poly tube factory pre-attached. If so, do not connect the tube to anything at this time. If the tube is not pre-attached, do not attach the poly tube to faucet at this time.

Figure 2.

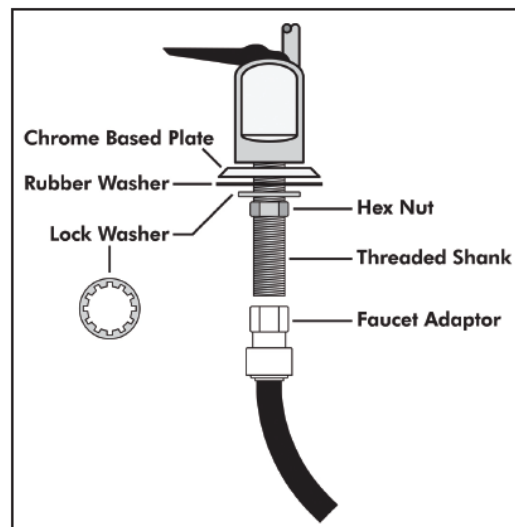

Step 5. Install the Drain Saddle Assembly

1. Select the location to install the drain saddle assembly. This is usually on the sink drainpipe and needs to always be located above the "S" trap.
2. Position the drain saddle assembly in the selected location and mark the spot through the threaded outlet with a pencil or marker
3. Drill a 1/4" hole at the marked spot. Strip the backing paper from the adhesive side of the saddle gasket and position on the inside of the drain saddle, aligning the hole with the threaded outlet. Attach the drain saddle to the drainpipe, aligning the push-on port with the drilled hole. Tighten the clamp snugly. **DO NOT OVER TIGHTEN.**
4. The black drain tube may be inserted directly into the push-on drain port, using instructions in Step 8 below. Do not attach poly tube at this time.

Figure 3.

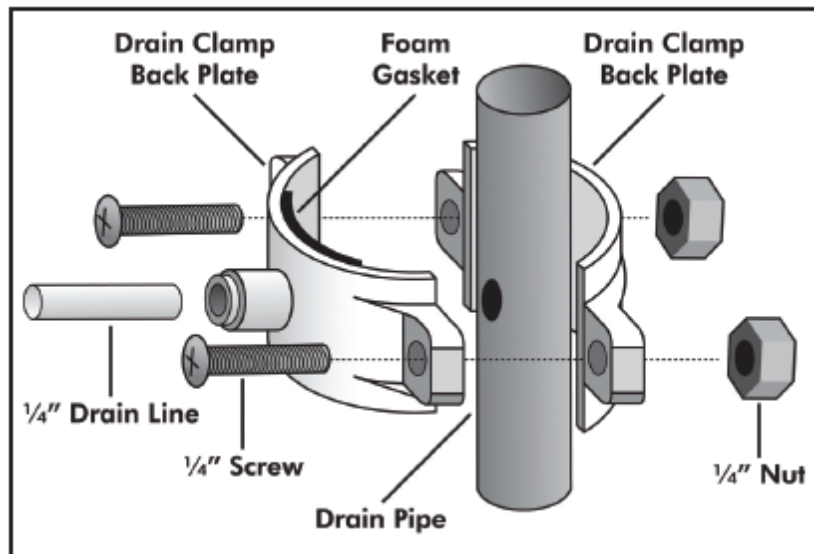

Step 6. Install the Tank Valve, Preparing the Storage Tank

1. Wrap the threaded storage tank nipple with two wraps of Teflon tape. Thread on tank shut-off valve until snug. Using the wrench, turn an additional 1/4 turn. **DO NOT OVER TIGHTEN.** Open tank valve to the fully open position.

Step 7. Mounting the RO Unit

1. While holding the RO unit in its mounting position, mark the holes for the wall screws. Using a 1/8" bit, drill the pilot holes for the screws. Screw in the mounting screws leaving 1/4" protruding. Hang the RO mounting bracket on the screws and tighten.
2. If the unit is to be mounted on wallboard, use plastic screw anchors, available at any builder's supply and follow the manufacturer's directions.
3. **DO NOT INSTALL FILTER CARTRIDGES AT THIS TIME.** Spin the filter housing bowls on to the RO unit and hand-tighten.

Step 8. Connect the System Tubing



READ THIS SECTION CAREFULLY. MOST SYSTEM LEAKS ARE CAUSED FROM IMPROPERLY COMPLETED PUSH-ON JOINTS.

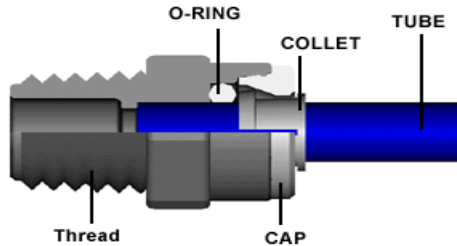

Making and securing a push on connection is simple. First, the tubing should be cut square and any burrs or rough edges removed. Insert the tube firmly and push until the tube end contacts the stop. Gently tug the tube backwards to assure a secure connection. To disconnect, pull the tube while pushing in the collet ring. The joint may be used over and over again, if necessary.

1. Connect the cold water supply valve to the first filter housing water inlet push-on fitting (marked "water inlet"), after cutting the ¼" clear tube to the length required. See addendums to this manual for installation of the **Leak Stop** flow interrupter and the shock arrestor/pressure regulating device (included in kit).
2. Connect the black ¼" tube (marked "to drain") to the Drain Saddle push-on connection (your black drain tube is pre-attached to your RO). Please note that the drain line flow restrictor has been installed INSIDE the black drain tube at the waste elbow, on the membrane housing. Place the storage tank in the location you have chosen for it. Using the clear ¼" tube connect the system fitting marked "to tank" to the tank valve. Connect the ¼" tube attached to the faucet to the system fitting marked "to faucet". If the tubing is not pre-attached to the faucet, cut the 3/8" clear tubing to the desired length and attach the tube to the fitting at the base of the faucet shank to the fitting marked "to faucet" on the RO unit.
3. You may find that your unit does not have labels attached to indicate the water line and drain line connections. The photos below are labelled with the correct locations for the water and drain connections.



Top View

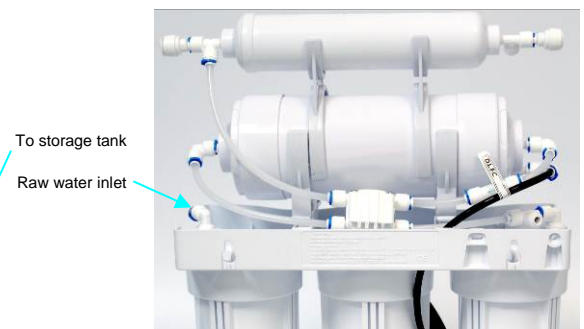

Back View

Step 9. Filling the System

!
THOROUGHLY WASH HANDS BEFORE LOADING CARTRIDGES AND MEMBRANE ELEMENTS.

Remove the PRE-FILTER housing bowl by turning counter clockwise with the housing wrench supplied. Remove all protective wrapping from the filter cartridges. Insert the white 5-micron sediment filter cartridge in the housing and reassemble housing. The housings are seated with o-rings – DO NOT OVER TIGHTEN – 1/4 turn after hand tight is usually sufficient. Repeat with the carbon block cartridge in the middle housing. Install another carbon block cartridge in the remaining filter housing and reassemble.



Step 10. Starting Up the System

1. Open cold water supply valve and let RO system fill with water. Check for leaks and tighten any joints if necessary
2. If a booster pump kit was installed, insert the plug into a standard wall receptacle. System pump will switch on and begin to operate.
3. Close the storage tank valve and open the faucet. Let the system operate for about 10 minutes or until product water drips out of faucet. Check for leaks again and fix if necessary.

!
DO NOT USE ANY WATER FROM THE SYSTEM UNTIL THE NEXT STEP IS COMPLETE.

4. Open the storage tank valve and close the faucet. The system is now operating and filling the storage tank. Allow the tank to fill completely and the system to automatically shut itself off. This step may take 1-3 hours or more. Open the faucet and let the entire tank drain completely. You will see dark carbon dust briefly flush from the post carbon filter cartridge – this is harmless and normal for the first flow of water through the cartridge. Allow the system to re-fill the tank. Once completed, your system is ready for use.

Section 3: Operation and Maintenance

Operation of your Reverse Osmosis System is simple and easy. This appliance is fully automatic and can be enjoyed without complicated operating procedures. Be sure to follow the cartridge replacement schedule to ensure peak performance and long membrane element life.

Changing Filter Cartridges and Sanitizing Procedure

The filter cartridges should be changed, as a rule of thumb, every three months. It is critical that this be done, to ensure that chlorine is not allowed to attack the membrane film.



THOROUGHLY WASH HANDS BEFORE LOADING CARTRIDGES AND MEMBRANE ELEMENTS.

1. Close the cold water supply valve. Open the faucet and completely drain until the flow of water stops. Remove the filter housing bowls with the housing wrench and discard the old filter cartridges (do not remove or replace the post carbon filter at this point). Thoroughly clean the inside of the housing bowls with soap and water. Rinse completely. Put ½ oz of RO cleaning solution (part#: ACCS-WCRF-0001) in the PRE-FILTER housing. Reassemble filter housings **WITHOUT** cartridges.
2. Disconnect the elbow fittings from the membrane housing, and replace the original membrane housing with the cleaning housing included with your RO system. Connect the elbow fittings to the cleaning housing.
3. Turn on the cold water supply valve and faucet, let system fill up with chlorinated water. Wait until water flows from faucet, then close faucet to allow tank to fill up. Wait approximately 5 minutes.
4. Turn the cold water supply valve OFF. Allow the system to stand for 1 hour.
5. Open the faucet and allow the system to completely drain. Disconnect the elbow fittings from the cleaning housing and put the original membrane housing back to the system by reversing the step 2. The system has now been sanitized and is ready to load the new cartridges.
6. To load the cartridges, repeat Step 9 from the installation instructions above. Replace the post carbon filter by disconnecting the both Tee fitting and faucet tube from the old filter, discarding the old filter and reconnecting the fitting and faucet tube to the new filter. Turn the raw water supply valve ON. Allow the storage tank to fill and then drain it completely and refill again before resuming use of the water system.

Changing the Reverse Osmosis Membrane

The membrane element will require changing much less frequently than the filter cartridges and only when failure is indicated. This should be done when water production begins to noticeably fall, or TDS readings in the product water begin to rise. **T**otal **D**issolved **S**olids may be measured by a professional or by use of a simple hand-held TDS monitor. These are available from your dealer or from Waterite's Online Store at www.waterite.com (the RO405400TNX comes with a TDS meter preinstalled).

The membrane element life will range from 1 to 5 years, depending on the quality of the raw water. Soft water free from iron is ideal. Hardness, iron, chlorine and infrequently changed filter cartridges are the membrane's greatest enemies.

To change the membrane element, start by closing the cold water supply valve. Open the faucet and completely drain until the flow of water stops. Disconnect the elbow fittings from each end of the membrane housing and remove the housing from the holding brackets. Replace the membrane housing and connect the elbow fittings back to the new membrane housing. Open the cold water supply valve and check for leaks and fix if necessary. Allow the tank to fill completely, when the tank is full, open the faucet and flush full tank of water and close the faucet and allow the tank to fill up again.

Your Warranty

Keep your bill of sale and your warranty certificate, included in this kit. This is needed to claim any parts or repair service during the warranty period. Read the document completely for warranty claim instructions.

!
BE SURE TO RETURN THE VECTAPURE WARRANTY CARD LOCATED IN YOUR LITERATURE KIT. THIS IS NECESSARY TO VALIDATE YOUR PRODUCT WARRANTY.

Section 4: Troubleshooting Guide

Trouble Shooting Guide

Possible Cause

Solution

Low Water or No Water

Water supply valve closed or tank valve closed.

Open valves

Low water pressure

Install booster pump

Crimped poly tube

Repair or replace tube

Raw water TDS high

Consult dealer – may need pre-treatment

Filters or membranes plugged

Replace filters

Tubes installed to wrong fitting

Install tubes per S.8 (1), (2) and (3).

Leaking Joints

Fittings not seated

Disconnect fitting and reseal tube

Filter housing leaking

Tighten with housing wrench
 Inspect o-rings for cuts or crimps

VECTAPURE NX™

RESIDENTIAL REVERSE OSMOSIS SYSTEM PARTS LIST

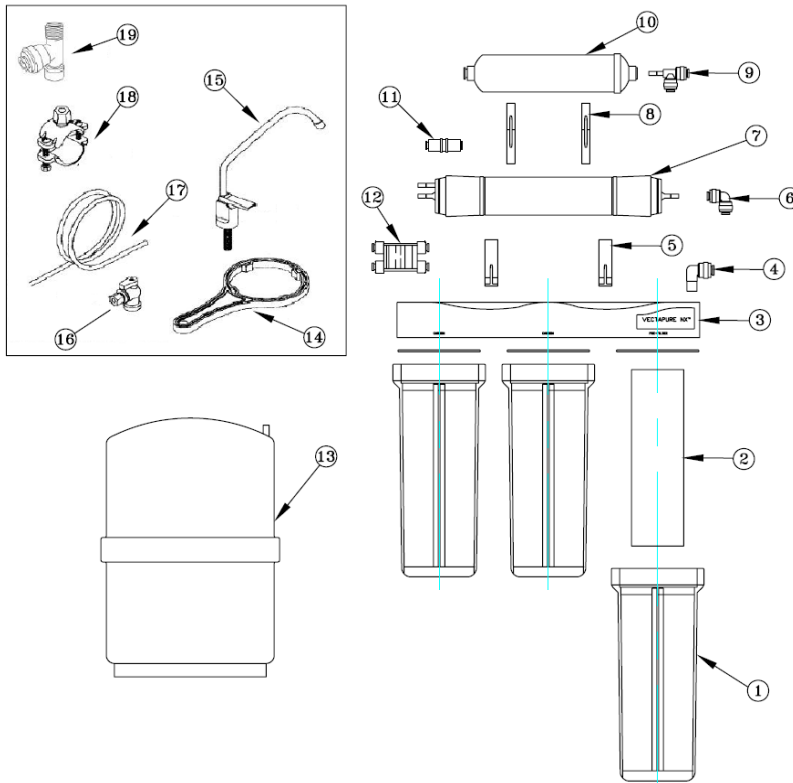

Vectapure NX™							
KEY	DESCRIPTION	PART NUMBER	COMMENT	KEY	DESCRIPTION	PART NUMBER	COMMENT
1	Filter housing	HA10W		10	Post carbon filter	AIC10EZ	
2	Cartridge 5 mic sediment	PP1005		11	Check valve	A4CV4	
	Cartridge, Carbon	CBC5CTO3		12	4-way shutoff valve	ROS002	
3	Mounting bracket	RO4053M		13	RO storage tank	ROT32P	
4	Male elbow, push-on, 1/4"	A4ME4		14	Plastic wrench	HAN06W	
5	Mounting clips	WP25		15	Faucet	F9C	
6	Elbow, push-on, 1/4"	A4EU4		16	Tank valve, push-on, 1/4"	A4HVFA4	
7	Encapsulated membrane	BME1812RE75		17	PE tube - 1/4"	3634100	clear
8	Mounting clips	WP225		18	Drain saddle	WP-14EZ	
9	Tee, push-on, 1/4"	EZT141414DT		19	Water supply adapter	ROTF3914	
NS*	Leak Stop flow interrupter	LS1414KAD		NS*	PRV/shock arrestor	REGP1414E	

Vectapure 400NX™							
KEY	DESCRIPTION	PART NUMBER	COMMENT	KEY	DESCRIPTION	PART NUMBER	COMMENT
1	Filter housing	HA10W		10	Post carbon filter	AIC10EZ	
2	Cartridge 5 mic sediment	PP1005		11	Check valve	A4CV4	
	Cartridge, Carbon	CBC5CTO3		12	4-way shutoff valve	ROS002	
3	Mounting bracket	RO4053M		13	RO storage tank	ROT32P	
4	Male elbow, push-on, 1/4"	A4ME4		14	Plastic wrench	HAN06W	
5	Mounting clips	CL05B		15	Faucet	F9C	
6	Elbow, push-on, 1/4"	A4EU4		16	Tank valve, push-on, 1/4"	EA3931	
7	Encapsulated membrane	BME3013SXL		17	PE tube - 1/4"	TU2C	clear
8	Mounting clips	CL04B		18	Drain saddle	WP14EZ	
9	Tee, push-on, 1/4"	EZT141414DT		19	Water supply adapter	ROTF3814	
NS*	Leak Stop flow interrupter	LS141KAD		NS*	TDS Monitor	HMDM2	RO405400TNX only
NS*	PRV/shock arrestor	REGP1414E					

VECTAPURE NX™

RESIDENTIAL REVERSE OSMOSIS SYSTEM FLOW LAYOUT

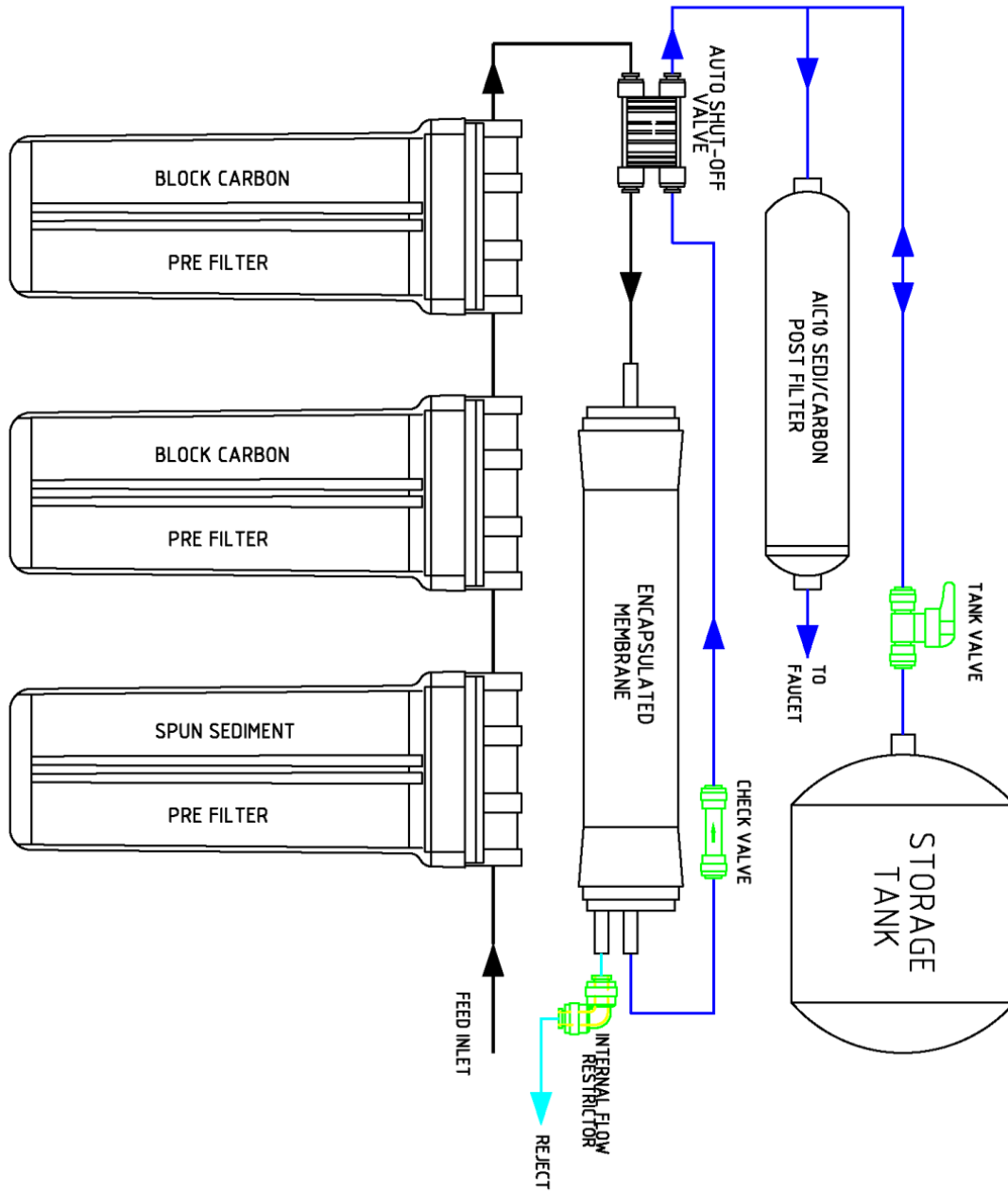

THIS PAGE HAS BEEN LEFT INTENTIONALLY BLANK

**VISIT THE WATERITE TECHNOLOGIES WEBSITE FOR INFORMATION,
CONSUMER ONLINE REPLACEMENT PARTS AND PRODUCT
UPDATES AT:
www.waterite.com**



WATERITE, INC

Winnipeg, Manitoba
Canada

www.waterite.com